

JOINT NO.	CLIP NO. #
JOINT-1	520(5X4)
JOINT-2	266(X3)
JOINT-3	318(3X6)
JOINT-4	312(3X4)
JOINT-5	318(3X5)

\* SANFORD GRIP - MASTER CLIPS OR EQUIVALENT APPLIED TO BOTH SIDES OF EACH JOINT.

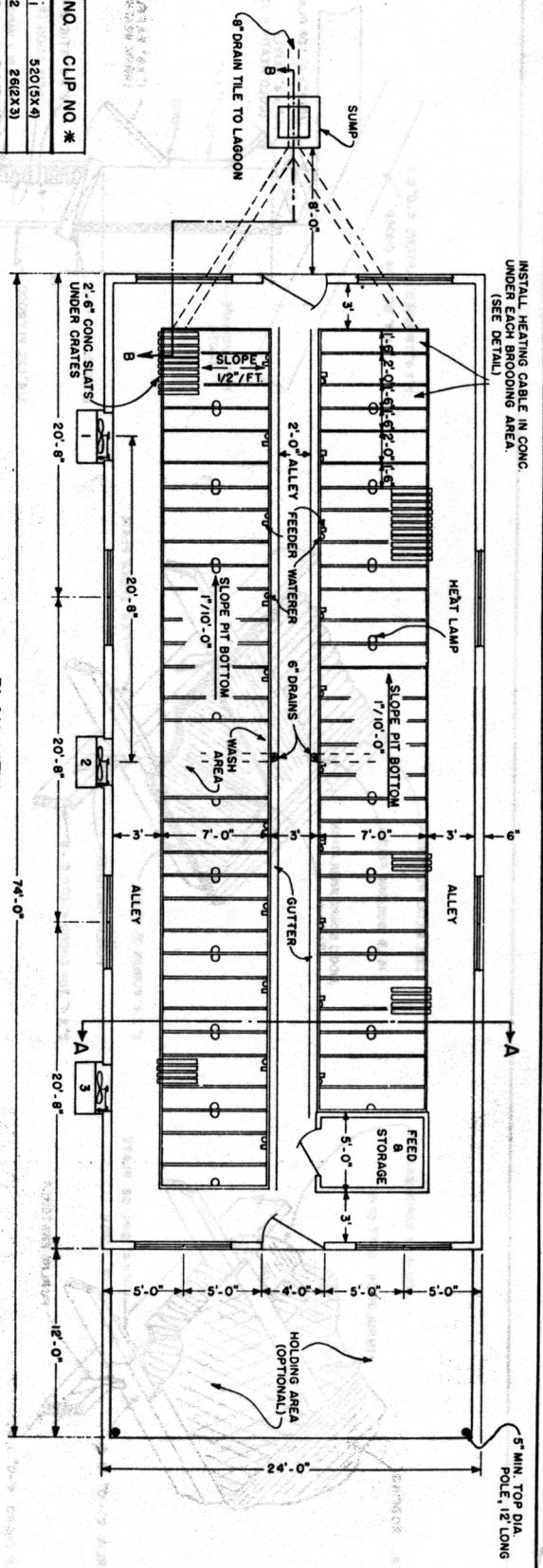

PLAN VIEW

SCALE: 0 2 4 6 8 FT.

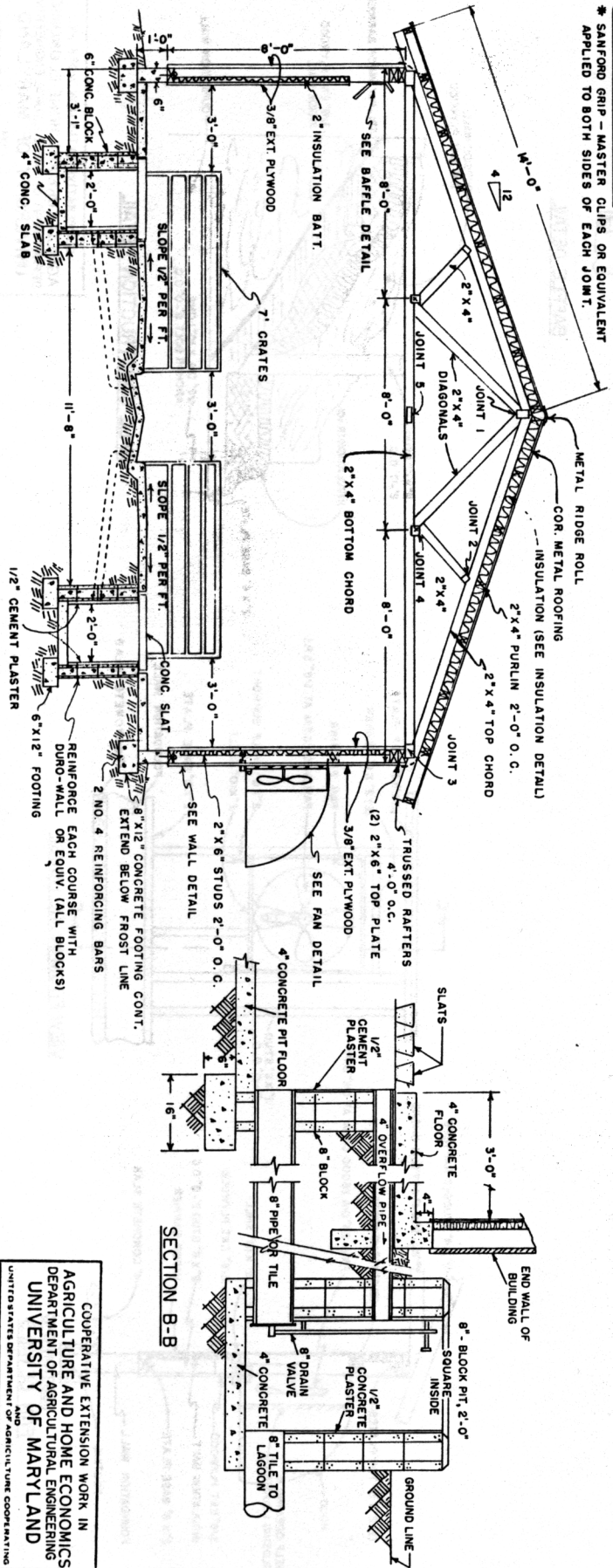

SECTION B-B

SECTION A-A

SCALE: 0 1 2 3 4 FT.

BASED ON: AUBURN UNIV. PLAN NO. J-117

COOPERATIVE EXTENSION WORK IN AGRICULTURE AND HOME ECONOMICS  
 DEPARTMENT OF AGRICULTURAL ENGINEERING  
 UNIVERSITY OF MARYLAND  
 UNITED STATES DEPARTMENT OF AGRICULTURE COOPERATING

**FARROWING HOUSE FOR SWINE**  
 ENVIRONMENTALLY CONTROLLED

ALA	71	6130	SHEET 1 OF 3
-----	----	------	--------------